

Yuchai Diesel Generator Set

Standby Power 1500KW/1875KVA, 50Hz@1500rpm, 400V, 3-PH



Main Technical Data

Genset Model:	BYF1500J
Prime Power:	1350KW / 1688KVA
Standby Power:	1500 KW / 1875KVA
Fuel consumption:	≤203g/KW.h
Engine:	Yuchai YC12VC2270-D31
Alternator:	Faraday FD7C-4
Controller:	Smartgen HGM6110N
Dimension for open type genset:	6500*2300*2600mm
Weight:	13350kg
Dimension for silent type genset:	12000*3000*3200mm

Features:

- Chinese Yuchai engine
- Advance digital Control system
- Anti Vibrating isolation
- 12 months warranty
- Low fuel consumption
- Heavy duty fabricated steel base frame

Benefits:

- Safe, Eco friendly
- Long service, life economical
- Smart; occupies little space
- Practical design, easy to operate
- People oriented, safety foremost
- High standard quality guaranteed

Standard specification

General features:

- Composed of rugged diesel engine.
- 24V DC start motor and storage battery.
- Brushless, Self-excited, IP23, Insulation class H alternator.
- Engine cooling system: Aftercooled.
- Key start panel control system as standard, digital auto-start panel is optional.
- Optional open type or silent type.
- All generator sets are gone through rigorous testing before being released to the market place, protection function (over speed stop, high water temperature, low oil pressure, battery charging fail, emergency stop)

Basic information:

- 1) **ESP**=Standby power standby duty, operation under variable load, without overload,
PRP= Prime Power Continuous duty operation, under variable load, 10% overload permissible 1/12hr.
- 2) **E**=Electronic speed governor.
- 3) **Asp**=Aspiration;
NA=Naturally Asp;
TC=Turbocharged;
TW=Turbocharged after cooled;
TCA=Turbocharged air-air after cooled.
- 4) Technical data is subject to work test conditions.

Reliable performance

Voltage Regulation

Voltage regulation maintained within $\pm 0.5\%$ as follow:

- Power factor between 0.8 ~1.0 lag
- From no load to full load, any steady load.
- Speed droop variation under 4.5%.

Frequency/speed undulation

- Change load from 0-100%, Frequency/speed droop ratio within 5%.
- Load from 25-100%, any steady load Frequency/Speed undulation within 0.25%.

Effect Factor of telecom

- TIF (MA MG1-22) better than 50.
- THF (BS EN60034) better than 2%.

Criterion

- EN 12601:2010, EN ISO12100:2010, EN60204-1:2006/AC:2010
- ISO9001:2015 Quality Management System
- ISO14001:2015 Environmental Management System

Dimension & Gross Weight (approximate)

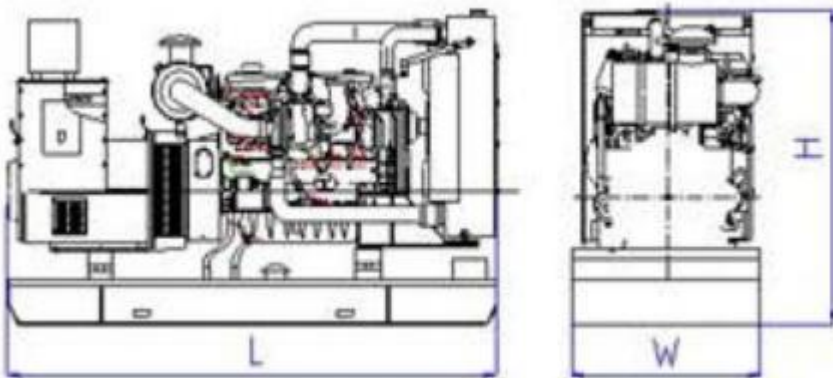

Open type

Overall size(L*W*H)
6500*2300*2600mm
13350 kg

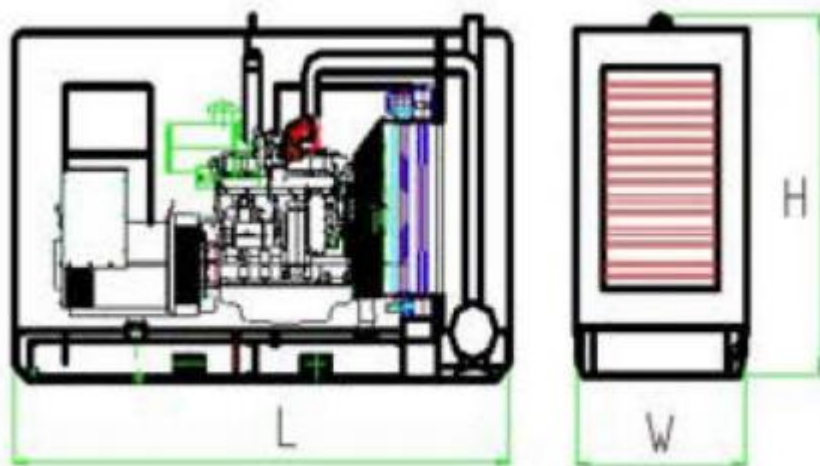

Silent type(optional)

Overall size(L*W*H)
12000*3000*3200mm
15500kg

Engine Technical Data

Engine model:	YC12VC2270-D31
Manufacture:	Yuchai, China
Prime/standby power:	1520KW/1670KW
Cylinders no. & Type:	12 cylinders in line, 4 cycle
Aspiration:	Turbocharging
Cooling system:	intercooling
Bore × Stroke:	200×210mm
Displacement:	79.17 L
Compression ratio:	13.5: 1
Speed Stability (%)	≤5%
Total Lubrication system capacity (L)	280L
Coolant capacity (for engine only) (L)	/
Approx. Fuel consumption at 75% load	/
Starter Motor	DC 24V

Alternator Technical Data

Brand :	Faraday
Model No.:	FD7C-4
Origin:	Wuxi, China
Prime power:	1350KW
Rated Voltage:	400V
Frequency & Rotated speed	50Hz/1500 rpm
Efficiency:	96.2%
Power Factor:	0.8
Regulator:	AVR(automatic voltage regulator)
Exciter Type:	PMG
Voltage regulation:	≤ ± 1%
Indication of protection:	IP23
Insulation class	H

Disclaimer: Manufacturer maintains the policy of continuous development and reserves the right to change the details shown on this data sheet without prior notice.

SmartGen Controller HGM6110N

Protection:

- ◆ High/low voltage & frequency.
- ◆ Revolving speed lack of /exceed.
- ◆ Low lubrication oil pressure.
- ◆ High water temperature.
- ◆ Over current/ short trouble, emergency stop



Standard Supply Scope:

- ◆ Drive fan for engine and 40°C heat radiating water tank.
- ◆ Moulded case circuit breaker
- ◆ Battery and battery cable
- ◆ Float battery charger
- ◆ Base frame with vibration isolator
- ◆ Exhaust elbow, exhaust bellows, exhaust muffler
- ◆ Fuel filter, oil filter, air filter
- ◆ Tool kits
- ◆ Plastic membrane packing
- ◆ English testing report, quality certificate, service manual and warranty card

Optional Supply Scope:

- ◆ Water jacket pre-heater
- ◆ Fuel and water separator
- ◆ Fuel pre-heater
- ◆ Base frame fuel tank
- ◆ External daily fuel tank
- ◆ ATS
- ◆ Synchronization system
- ◆ Standard container
- ◆ Rain-proof canopy
- ◆ Sound-proof canopy
- ◆ Trailer

